

---

# **Appendix A – WDT1304**

---

## **Queue Cluster 8 Phase II Report**

**November 23, 2016**

This study has been completed in coordination with the California Independent System Operator Corporation (ISO) per Southern California Edison Company's Wholesale Distribution Access Tariff (WDAT), Attachment I Generator Interconnection Procedures (GIP)

## Table of Contents

<b>A.</b>	<b>Introduction .....</b>	<b>1</b>
<b>B.</b>	<b>Study Assumptions.....</b>	<b>4</b>
<b>C.</b>	<b>Reliability Standards, Study Criteria and Methodology .....</b>	<b>8</b>
<b>D.</b>	<b>Power Flow Reliability Assessment Results .....</b>	<b>8</b>
<b>E.</b>	<b>Short-Circuit Duty Results.....</b>	<b>16</b>
<b>F.</b>	<b>Preliminary Protection Requirements .....</b>	<b>16</b>
<b>G.</b>	<b>Transient Stability Evaluation .....</b>	<b>16</b>
<b>H.</b>	<b>Deliverability Assessment Results .....</b>	<b>17</b>
<b>I.</b>	<b>In-Service Date and Commercial Operation Date Assessment .....</b>	<b>17</b>
<b>J.</b>	<b>Timing of Full Capacity Deliverability Status, Interim Deliverability, Area Constraints, and Operational Information .....</b>	<b>19</b>
<b>K.</b>	<b>Distribution Provider’s Interconnection Facilities, Network Upgrades, and Distribution Upgrades .....</b>	<b>19</b>
<b>L.</b>	<b>Cost and Construction Duration Estimates .....</b>	<b>20</b>
<b>M.</b>	<b>SCE Technical Requirements.....</b>	<b>20</b>
<b>N.</b>	<b>Environmental Evaluation, Permitting, and Licensing .....</b>	<b>20</b>
<b>O.</b>	<b>Affected Systems Coordination .....</b>	<b>20</b>
<b>P.</b>	<b>Items not covered in this study .....</b>	<b>20</b>

### Attachments:

1. Interconnection Facilities, Network Upgrades, and Distribution Upgrades
2. Escalated Cost and Time to Construct for Interconnection Facilities, Reliability Network Upgrades, Delivery Network Upgrades, and Distribution Upgrades
3. Not Used
4. SCE Interconnection Handbook
5. Short-Circuit Duty Calculation Study Results (see Appendix H of the Area Report)
6. Not Used
7. Not Used
8. Subtransmission Assessment Report – Villa Park 66 kV System

## A. Introduction

██████████ the Interconnection Customer (IC), has submitted a completed Interconnection Request (IR) to Southern California Edison Company (SCE) for their proposed ██████████ (Project). The Project requested a Point of Interconnection (POI) at Distribution Provider's Pink 12 kV Circuit, located in Orange, CA. The IC elected to be an Option B Generating Facility (GF) with Full Capacity Deliverability Status (FCDS) for their Project. The IC desires an In-Service Date (ISD) of November 2018<sup>1</sup> and a Commercial Operation Date (COD) of December 2018. Such dates are specified in the Project's Attachment B to the Generator Interconnection Study Process Agreement. Actual ISD and COD will depend on licensing, engineering, detailed design, and construction requirements to interconnect the Project to Distribution Provider's Distribution System; after the Generator Interconnection Agreement (GIA) has been executed and filed at the Federal Energy Regulatory Commission (FERC) for acceptance.

In accordance with FERC approved SCE's WDAT Attachment I GIP, the Project was grouped with Queue Cluster 8 (QC8) Phase II projects to determine the impacts of the group as well as impacts of the Project on the ISO Grid.

An Area Report and Subtransmission Assessment Report have been prepared separately identifying the combined impacts of all projects in the Metro Area and served out of the Villa Park 66 kV Subtransmission System, respectively. This Appendix A report focuses only on the impacts or impact contributions of the Project at the local Distribution System, and it is not intended to supersede any contractual terms or conditions specified in the GIA.

The report provides the following:

1. Distribution system impacts caused by the Project.
2. System reinforcements necessary to mitigate the adverse impacts caused by the Project under various system conditions.
3. A list of required facilities and a good faith estimate of the Project's cost responsibility and time to construct<sup>2</sup> these facilities. Such information is provided in Attachment 1 and Attachment 2 as separate documents in the Appendix A Project report package.

Additionally, the Project encompasses energy storage equipment that required additional analysis to be performed in order to evaluate the impacts of the charging facility within Distribution Provider's distribution system. These analyses focused on the charging<sup>3</sup> aspects of the charging facilities and consider varying levels of system demand with minimal generation dispatch within the local Distribution System.

---

<sup>1</sup>The IC provided Attachment B with revised ISD and COD which are sooner than the dates provided in the original Interconnection Request.

<sup>2</sup> It should be noted that construction is only part of the duration of months specified in the study, which includes detailed engineering, licensing, and other activities required to bring such facilities into service. These durations are from the execution of the GIA, receipt of: all required information, funding, and written authorization to proceed from the IC as will be specified in the GIA to commence the work.

<sup>3</sup> Charging is defined as when the Project draws energy from the grid to "charge" the Project-associated charging facilities.

Consequently, the report also discloses the adequacy of Distribution Provider’s distribution system to support the charging aspects of the charging facilities, identifies system limitations that may restrict the charging facility’s ability to charge during certain demand conditions, and provides a high-level explanation of potential exposure to charging restrictions on the distribution system in addition to identifying distribution system improvements, which would mitigate such restrictions to charging.

All the equipment and facilities comprising the Generating Facility are located in Orange, CA, as disclosed by the IC in its IR. The Generating Facility, as may have been amended during the Interconnection Study process, consists of (i) [REDACTED] each for a combined gross/rated output of [REDACTED] with an auxiliary load of [REDACTED] for a total net output of 7.9 MW, (ii) the associated infrastructure, (iii) meters and metering equipment, and (iv) appurtenant equipment.

The Project shall consist of the Generating Facility and the IC’s Interconnection Facilities as illustrated below in Figure A.1. Below also is Figure A.2, a map that illustrates the location of the Project. Moreover, the Project information is summarized in Table A.1 below. Please note the Project shall not exceed the total net output of 7.9 MW at the POI.

Figure A.1: Project Plan of Service (POS)

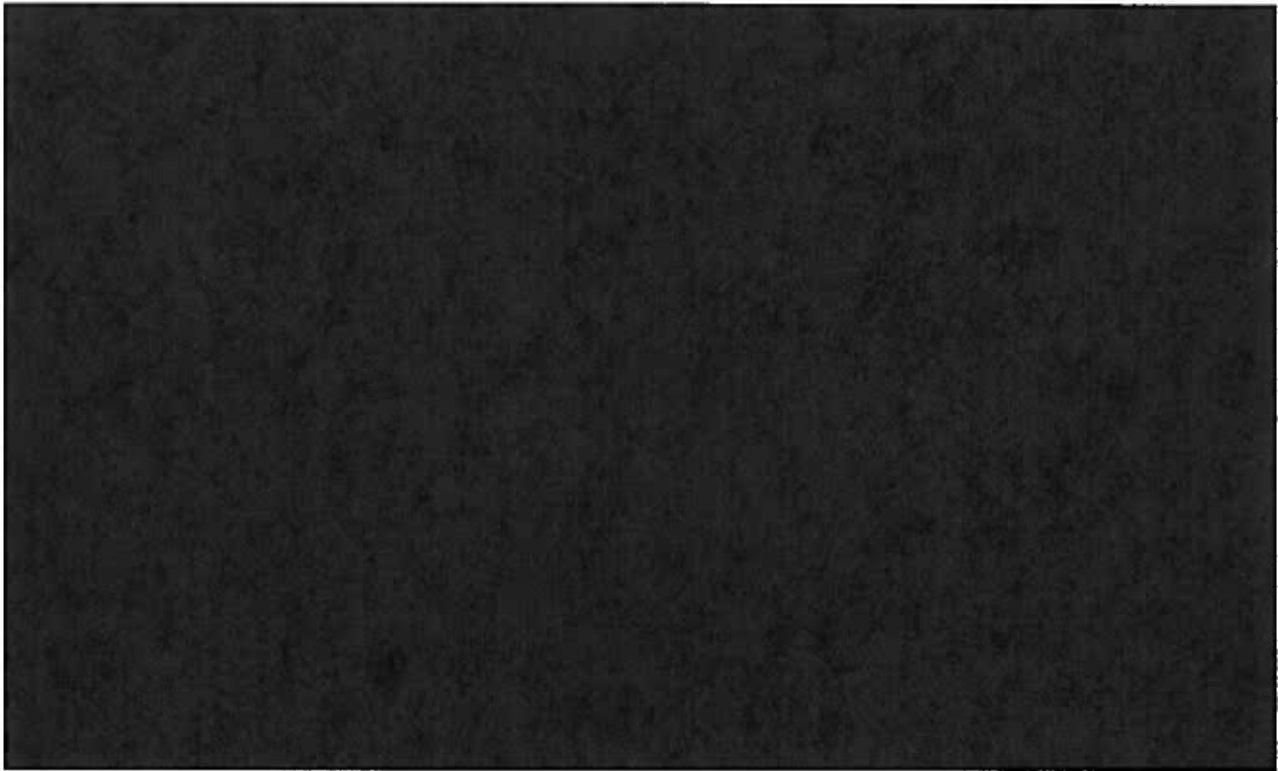

Figure A.2: Project Location Map

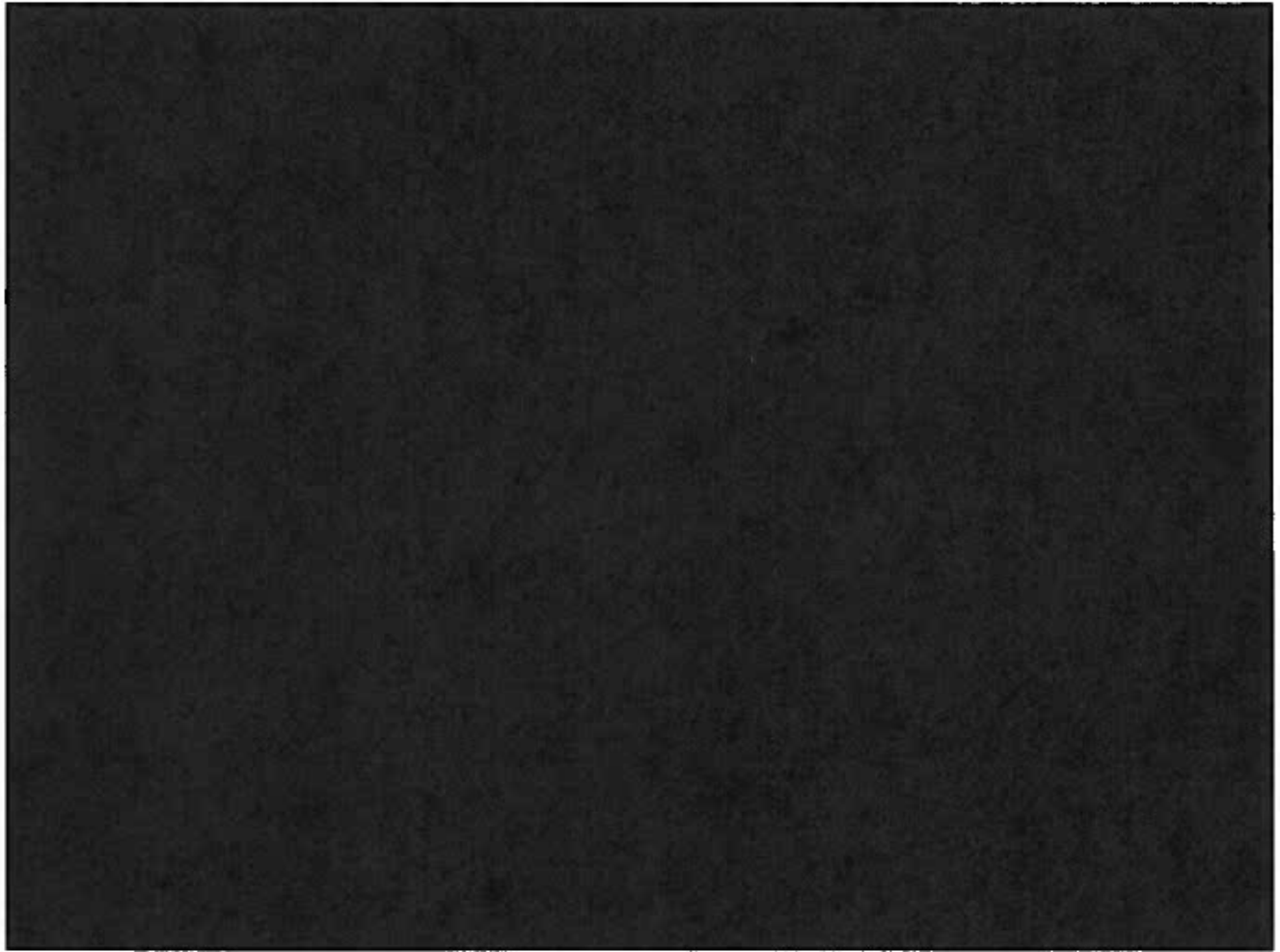

Table A.1 Project General Information per IR

Project Location	[REDACTED]
Distribution Provider's Planning Area	Distribution Provider's Metro Area
Number and Types of Generators	[REDACTED]
Interconnection Voltage	12 kV
Maximum Generator Output	[REDACTED]
Generator Auxiliary Load	[REDACTED]
Maximum Net Output at Generating Facility	7.9 MW
Power Factor Range	[REDACTED]
Step-Up Transformer(s)	[REDACTED]
POI	Pink 12 kV Circuit
ISD	November 2018
Initial Synchronization Date/Trial Operation	November 2018
COD	December 2018

Based on the technical data provided, the Project is requesting to install more megawatts (8.8 MW) as measured at the inverter terminal which will result in more than the requested 7.9 MW delivery at the POI. As a result, the Project will need to be limited to not exceed the values shown under Limited Maximum Net Output (metered on high-side of the main transformer bank).

## B. Study Assumptions

For detailed assumptions regarding the group cluster analysis at the transmission and subtransmission level, please refer to the applicable Area Report and Subtransmission Assessment Report. Below are the assumptions specific to the Project:

1. The Plan of Service (POS) is defined as the facilities needed to interconnect the Project to Distribution Provider's distribution system. The following is the POS assumed for the Project:

The Project was modeled as interconnecting 7.9 MW of energy storage through the Pink 12 kV Circuit out of Orange 66/12 kV Substation bus.

2. The following facilities will be installed by the Distribution Provider and are included in this Interconnection Study report:

- Replace two (2) distribution poles and risers
- [REDACTED]
- [REDACTED]
- [REDACTED]
- [REDACTED]
- [REDACTED]
- 12 kV Primary Metering and associated wiring
- Telemetry – Centralized Remote Terminal Unit (RTU)
- Retail and wholesale load meters

NOTE: Distribution Provider installation does not include metering, potential transformers (PTs) and current transformers (CTs). The Distribution Provider meters will be connected to the generator-owned PTs and CTs to be installed for their ISO metering.

3. The following facilities will be installed by the IC and are not included in this Phase II Interconnection Study report:

- Ducts as required
- Structures as required
- 12 kV primary switchgear
- Isolating circuit breaker
- Protection System requirements to comply with the Distribution Provider’s Interconnection Handbook
- Transformation as required
- Metering Equipment compliant with Distribution Provider’s Electrical Service Requirements
- The required metering cabinet
- The required ISO metering equipment, potential transformers (PTs) and current transformers (CTs) and ISO meters and metering cabinet for Distribution Provider retail and wholesale load meters.

NOTE: The Distribution Provider will install metering, PTs and CTs to be used for the Distribution Provider owned retail and wholesale meters. The PTs and CTs can be used for the ISO metering.

4. Environmental Activities, Permitting, and Licensing

There is no environmental component associated with this Project.

## 5. SCE's System Topology

The topological structure of SCE's transmission lines, substations, and subtransmission lines is depicted below to provide an overview of SCE's Transmission and Distribution Systems pursuant to this study.

Figure 2-1: Topology of SCE's Electric System

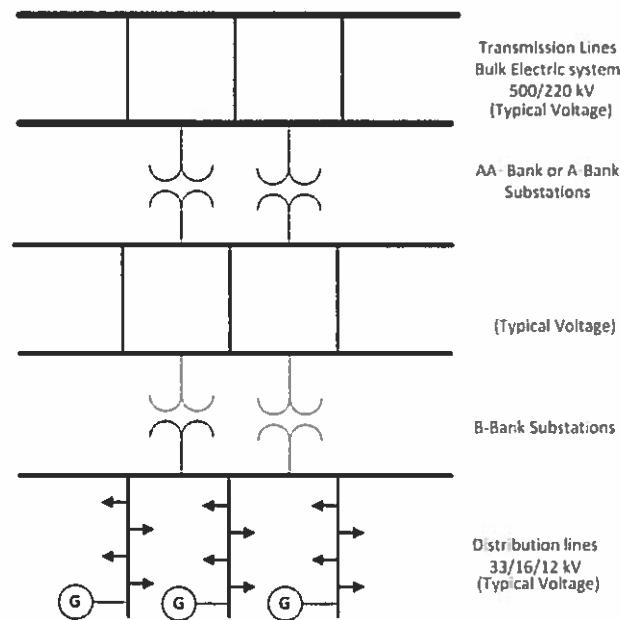

## 6. The following SCE Distribution System Planning Criteria and Conditions were included in the Phase II Study:

- Distributed generation resources connected to the distribution system are analyzed offline and online during peak load conditions as well as during minimum daytime load conditions as to determine the worst case scenario.
- The short-circuit duty contribution from the inverter systems was determined using inverter manufacturer documents.
- The Study assumes the upgrades triggered by queued-ahead projects, including Rule 21 projects under California Public Utilities Commission (CPUC) jurisdiction as In-Service, are included in the base case. If any queued-ahead projects were to withdraw, then the projects may be subject to the cost identified for those queued-ahead projects.
- Current distribution design standards are being updated to address generation interconnection systems. The proposed POS in this report may change according to detailed design in order to comply with the updated Distribution design standards.

## 7. Charging Facility Considerations:

- Distribution Provider's Distribution Standards and practices are in the process of being updated to address charging facilities. The proposed POS in this report may require changes to comply with the updated distribution design standards and practices.



- This study assumes that the Generating Facility will include all equipment, software, appropriate controls, and other related equipment necessary to maintain the charging facility demand profile per Distribution Provider requirements.
- Upon execution of the GIA, Distribution Provider will provide the IC with the required ramp rate<sup>4</sup> control parameters and other necessary information to allow the customer to develop its storage control limit.
- Ongoing changes to the ramp rate control scheme may be required as determined by changes in the distribution system topology or other changes in the distribution system. However, typical ramp rates for facilities connected to Distribution Provider's Distribution System are 10% of nameplate rating, per minute.
- A Storage Management System (SMS), which at this stage is conceptual, is under development to incorporate the increased amount of energy storage applications to SCE's Distribution System with minimal Distribution Upgrades. It is assumed that a SMS will not be available prior to the In-Service Date (ISD) of the generating/ charging facility. Further details will be available during the engineering and design phase of the Project. Conceptually, the SMS is a system composed of communication equipment, customer equipment, SCE equipment and logical algorithms which together will actively communicate the allowable charging limits to the customer storage project control system. The levels of allowable charging will be based on the capacity of the distribution system components at the circuit, substation and A-bank levels as to maintain safe and reliable operation of the distribution system.
- The facilities and costs to implement the SMS are included in Attachments 1 and 2. In order to ensure storage charging capabilities limits and restrictions are communicated in a timely and reliable manner, the IC is responsible for providing reliable communications yet to be identified equipment at an agreed location within the project location. The agreed on location for communication interphase will be based on the requirements outlined within SCE's Interconnection Handbook (Telemetry section). Should the communication channel fail, the Project's operating limits will automatically revert to zero (no charging allowed) or previously determined charging schedule.
- The use of "charging" restrictions (or curtailment of charging facilities), in lieu of physical upgrades, are considered a viable alternative for this charging study<sup>5</sup> provided such restriction is implemented as part of the SMS. Any restrictions identified here are purely projections, and the SMS mentioned above will need to be installed as an upgrade to determine the storage demand limits for the charging facility. However, per the aforementioned section, the storage management system will need to be further assessed and will only be allowed if it is ultimately determined that actual implementation is feasible for Distribution Provider's real-time system operations.
- The Project encompasses charging facilities. The details pertaining to the Power Flow Reliability Assessment Results for the charging of the Project's charging facilities are included in this Appendix A report and applicable Subtransmission Assessment Report.

---

<sup>4</sup> It is assumed that ramp rates for each charging facility will be dependent upon their inherent technology types. While very quick response ramp rates (i.e. going from full charge to full discharge instantaneously, or vice-versa) may be beneficial for other grid services, the Distribution Provider, may, at its discretion, require establishing limits to maintain safety and reliability of its Distribution System.

<sup>5</sup> The advent of distribution-connected energy storage brings with it challenges for utility planners, system operators, and regulatory/jurisdictional issues. More specifics of how the management systems of the future grid are to function will develop as progress is made in all of the aforementioned areas.

- The energy storage component of the Project will need to be metered separately. The IC should be prepared to install multiple sets of metering (i.e. separate sets of potential transformers & current transformers and supporting metering equipment) for the Project.

### C. Reliability Standards, Study Criteria and Methodology

#### 1. Discharge Analysis Planning Criteria

Refer to above Section B: Study Assumptions for the reliability standards, study criteria and methodology applied in this study.

#### 2. Charging Analysis Planning Criteria

This study was conducted by applying SCE’s Distribution Planning Criteria. More specifically, the key criteria applicable to this Phase II Study are as follows:

- The thermal rating of any conductor, connector, or apparatus shall not exceed 100% of its normal rated capacity<sup>6</sup> with all facilities in service (N-0 or base case).
- The thermal rating of any conductor, connector, or apparatus shall not exceed 100% of its emergency rated capacity under loss of one element (N-1) condition(s).
- The thermal rating of any B-Bank shall not exceed 100% of its nameplate rated capacity with all facilities in service (N-0 or base case).
- The thermal rating of any B-Bank shall not exceed 100% of its nameplate rating capacity under loss of one element (N-1) or emergency condition(s).
- Operational flexibility, safety, and reliability of the distribution system shall be maintained at all times.
- Circuit voltage profiles shall be maintained to comply with SCE’s CPUC Jurisdictional Rule 2 tariff requirements. The IC will be responsible for maintaining designated voltage levels under all conditions, including but not limited to the conditions identified above.
- The power factor for the energy storage system facility is assumed to be within WDAT requirements of [REDACTED]
- Expected loading on the distribution system as projected by SCE’s internal 2016-2025 distribution system forecast is utilized for the purposes of this charging analysis.
- Charging facilities connected to the distribution system are analyzed offline (pre-project) and online (post-project) during peak demand conditions, as well as during absolute minimum demand conditions, as to determine the worst case scenario between these two “book-ends” of demand.

### D. Power Flow Reliability Assessment Results

#### Discharging Analysis of the Project

##### I. Steady State Power Flow Analysis Results – 220 kV and above

The group study indicated that the Project does not contribute to any overloads/non-convergence problems on the transmission system of the area. Consequently, the Project did not get allocated costs for any Network Upgrades. Refer to enclosed Area Report in the report package for the Phase II power flow analysis results.

---

<sup>6</sup> Normal rated capacity or Planned Loading Limit (PLL) capacity is determined by the lesser of the limiting component on the distribution system or 75% of minimum trip of the upstream protection device.

## II. Steady State Power Flow Analysis Results – 66 kV

The Subtransmission assessment indicated that the Project does not contribute to any overloads/non-convergence problems on the Subtransmission system of the area. Consequently, the Project did not get allocated costs for any upgrades at the Subtransmission level. Refer to enclosed Subtransmission Assessment Report in the report package for the Phase II power flow analysis results.

## III. Steady State Power Flow Analysis Results – 33 kV and below

### 1. Thermal Overloads

The distribution level study indicated that the Project did not contribute to the facility overloads or non-convergence problems.

- Base Case (All facilities in service, N-0)
  - [REDACTED]
    - No thermal overloads have been identified
  - [REDACTED]
    - The addition of the Project did not cause a thermal overload
- Single Contingency (loss of a single element, N-1)
  - [REDACTED]
    - No thermal overloads have been identified
  - [REDACTED]
    - The addition of the Project did not cause a thermal overload
- Due to the dynamic distribution system conditions and configurations, under emergency N-1 conditions (loss of a B-Bank, or loss of the [REDACTED] the Distribution Provider may deem it necessary to open the source to remove the Project from Distribution Provider's Distribution System. Once the Distribution Provider system is restored to normal, the Distribution Provider would then close in the source and the generation system can resume normal operation.

### 2. Power Flow Non-Convergence

There were no non-convergence issues identified with the inclusion of the Project.

### 3. Voltage Performance

The [REDACTED] is not expected to experience a voltage rise that exceeds allowable Rule 2 requirements with the Project in service. The Project is expected to operate at unity power factor with the capacity to provide power factor regulation capability [REDACTED] to alleviate power flow non-convergence and maintain the transmission transfer capability. Additionally, the generation system must be designed to accommodate a VAR schedule provided by the Distribution Provider. The Distribution Provider will determine if the VAR schedule is necessary based on future re-arrangements of Distribution Provider's Distribution System.

4. Protection

- [REDACTED]
  - I. The addition of the Project resulted in inadequate protection of the Distribution Provider's Distribution System. [REDACTED]  
[REDACTED]  
[REDACTED]
- [REDACTED]
  - II. The addition of the Project resulted in inadequate protection of the Distribution Provider's Distribution System. [REDACTED]  
[REDACTED]  
[REDACTED]

5. Required Mitigations

Per the WDAT, the Project is required to provide [REDACTED] capability at the POI, in addition to the facilities listed in B.2 and the following Distribution Upgrades (DUs) to mitigate the power flow impacts of the Project described above under Voltage Performance.

Refer to Attachment 1 and Attachment 2 for scope description and associated project cost responsibility of these Distribution Upgrade(s) and Protection.

Charging Analysis of the Project

- I. **Steady State Power Flow Analysis Results – 220 kV and above**

The group study indicated that the Project does not contribute to any overloads/non-convergence problems on the transmission system of the area. Consequently, the Project did not get allocated costs for any Network Upgrades. Refer to enclosed Area Report in the report package for the Phase II power flow analysis results.
- II. **Steady State Power Flow Analysis Results – 66 kV**

The subtransmission assessment indicated that the Project contributes to overloads/non-convergence problems on the Villa Park 66 kV Subtransmission System of the area. Consequently, the Project has been allocated a Storage Management System to help mitigate the power flow impacts on the subtransmission system. Further details are provided in Section III below. Refer to enclosed Subtransmission Assessment Report in the report package for the Phase II power flow analysis results.
- III. **Steady State Power Flow Analysis Results – 33 kV and below**

The load assumptions used for Distribution Provider's Distribution System considers SCE's 2016-2025 Distribution Load Forecast and the previous two (2) years of historical data.

To model the hourly forecast demand performance of Distribution Provider's Distribution System, historical year 2015-2016 B-Bank and circuit data were obtained and adjusted to reflect the worst case year within SCE's Distribution Load forecast. The use of historical data established a baseline upon which to build a comparable hourly demand performance for the worst case year in SCE's Distribution Load Forecast.

Note: Due to the dynamic nature of the Distribution Provider's distribution system, the operational limitations yielded by the charging analysis results disclosed in this report are for informational purposes only. Furthermore, the charging analysis used historical system performance information, which can only speak to past system performance. Hence, the charging analysis results cannot establish hard conditions for future real time operational conditions in which the Project's charging are restricted.

## 1. Thermal Overloads

The distribution level study indicated that the Project contributes to the following facility overloads or non-convergence problems. The details of the analysis and overload levels are provided in the area study.

- Base Case (All facilities in service, N-0)
  - [REDACTED]
    - The addition of the Project resulted in a thermal overload of the duct banks inside the substation. [REDACTED]  
[REDACTED]  
[REDACTED]
  - [REDACTED]
    - The addition of the Project resulted in a thermal overload of the duct bank on the [REDACTED]  
[REDACTED]  
[REDACTED]
- Single Contingency (loss of a single element, N-1)
  - [REDACTED]
    - No thermal overloads have been identified
  - [REDACTED]
    - No thermal overloads have been identified
- Note: Under emergency N-1 conditions (loss of a B-Bank, or loss of the [REDACTED] [REDACTED] no thermal overloads were triggered by the Project. However, due to the dynamic distribution system conditions and configurations, the Distribution Provider may deem it necessary to open the source gas switch to remove the Project from the Distribution Provider's Distribution System, in order to reduce bank loading or line loading to its normal ratings. Once the Distribution Provider's system is restored to normal, the Distribution Provider would then close the gas switch and the generation system can resume normal operation.

## 2. Power Flow Non-Convergence

There were no non-convergence issues identified with the inclusion of the Project.

## 3. Voltage Performance

### I. Individual Project Power Factor Requirements

Based on the results of the Study, the Project will need to be designed to maintain a composite power delivery at continuous rated power at the POCO at a power factor within the range of [REDACTED]. Additionally, the generation system must be designed to accommodate a Voltage/VAR schedule provided by the Distribution Provider. The Distribution Provider will determine if the Voltage/VAR schedule is necessary based on future re-arrangements of the Distribution Provider's system.

II. Distribution System Power Factor Requirements – 34.5 kV or below

[REDACTED] is not expected to experience a voltage rise that exceeds Rule 2 requirements with the Project in service.

4. Protection

- [REDACTED]
  - No additional protection requirements are triggered by the charging aspect of the Project.
- [REDACTED]
  - No additional protection requirements are triggered by the charging aspect of the Project.

5. Charging Restrictions

I. System Condition

- Base Case (All facilities in service, N-0)

Based on the assessment results of the system loading projections, there were charging restrictions identified for the Project. The charging restrictions are a function of system loading conditions and load forecast. Modification or adjustments to the charging restrictions will be evaluated as required by SCE to maintain its distribution system within operating criteria. These modification or adjustments reviews may be completed on yearly basis, at any time when significant load is added to the distribution system or as determined necessary by SCE. These reviews may trigger the storage charging capabilities. Assuming adjusted 2015-2016 historical demand patterns adequately represent worst case year within SCE's Distribution Load forecast performance, the evaluation identified the need to restrict charging during portions of the day, month, and year. The need to restrict charging will increase over time as normal system demand continues to grow. See tables below for projected charging forecast.

- Single Contingency (loss of a single element, N-1)

- [REDACTED]
  - At this time, the available capacity at the substation allows the Project to charge with restrictions.

- [REDACTED]  
At this time, the available capacity at the circuit to allow the Project to charge with restrictions.

Note: Under emergency conditions, [REDACTED] will be de-energized resulting in disconnection of the Project(s). Additionally, due to the dynamic distribution system conditions and configurations, the Distribution Provider may deem it necessary to disconnect the Project under N-1 conditions on other distribution circuits (if abnormal) until the distribution system returns to normal conditions.

## II. Additional Factor(s) to Restrictions

It is important to note that the increased risk of restrictions is not only based on load forecast, load growth, and demand performance assumptions but are also based on the feasibility of implementing real-time system information and ability to use the SMS as means of maximizing the loading limit that can be accommodated. The SMS would limit amount of charging to stay within the limits of the Distribution Provider's equipment ratings.

Utilizing the adjusted hourly demand performance shown above in Figure 2-2, the estimated number of hours that the charging facility may be restricted to charge at a given demand value in a given month are shown below. This is subject to change as loading on the system changes. Note that charging restrictions illustrated in the tables below are for the respective areas within the distribution system (i.e. distribution substation or distribution circuit). The Project's charging restrictions will be based on the most restrictive conditions and real time information from the distribution and transmission system.

Table 2-1: [REDACTED]  
# of Charging Hours Restricted for SMS

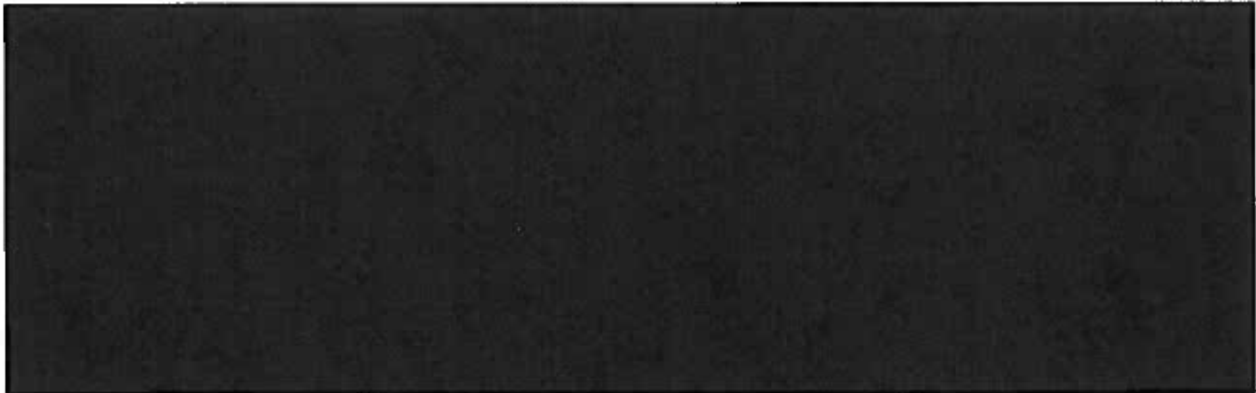

Table 2-2: [REDACTED]  
Charging Hour Restrictions of Day for SMS

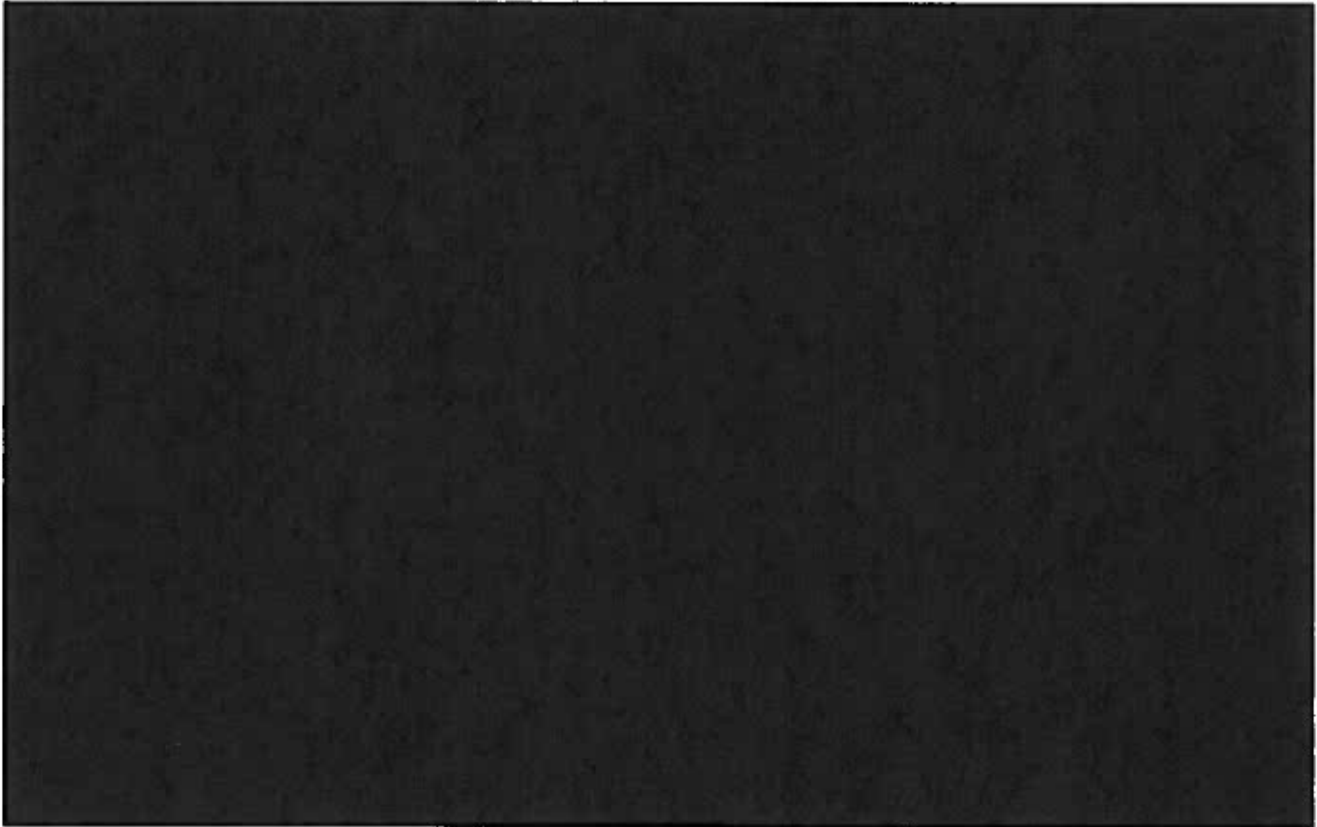
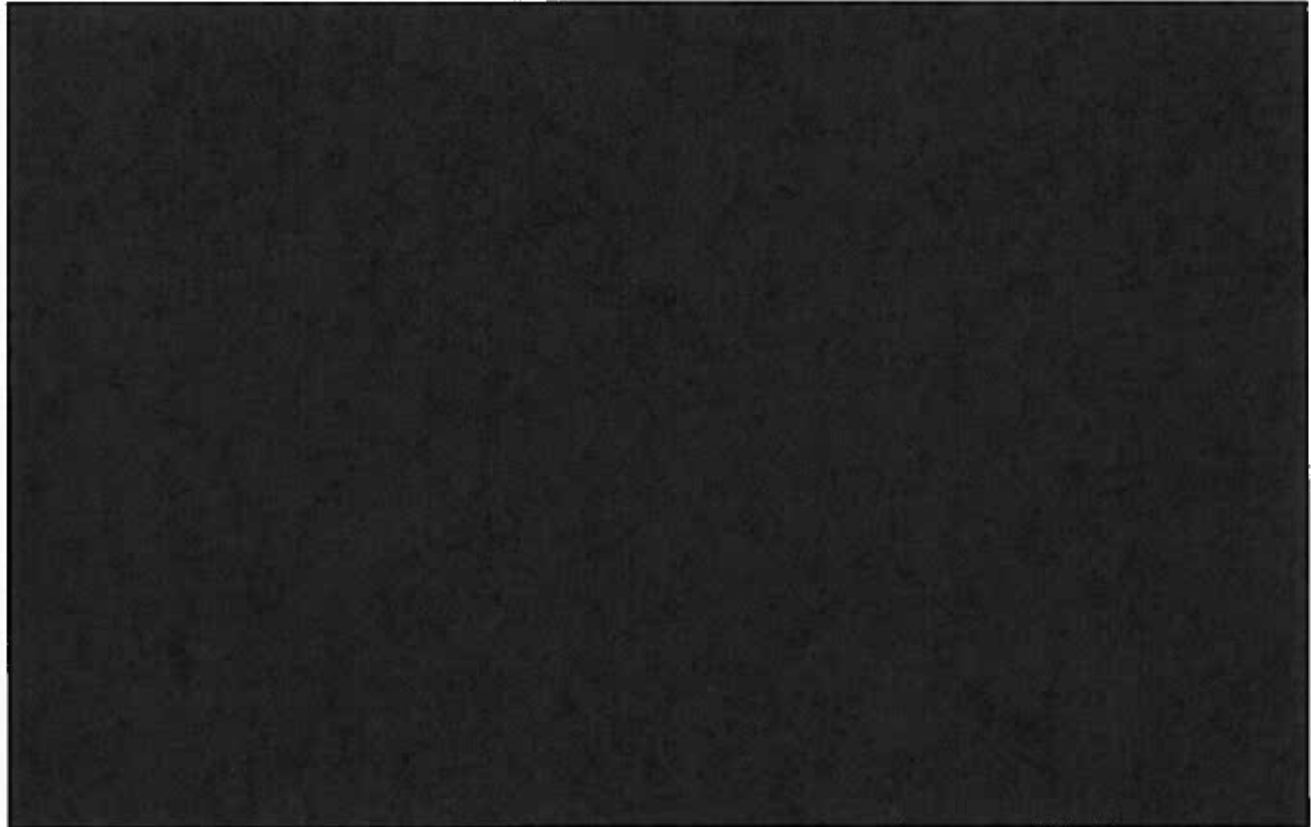

Table 3-1: [REDACTED]  
# of Charging Hours Restricted for SMS





Table 3-2: [REDACTED]  
Charging Hour Restrictions of Day for SMS



**6. Required Mitigations**

The Project is required to provide [REDACTED] power factor regulation capability at the POI, in addition to the following Distribution Upgrade(s) to mitigate the power flow impacts of the Project described above under Voltage Performance.

**I. Storage Management System (SMS)**

The SMS is needed for loss of a B-bank transformer or the [REDACTED]. [REDACTED] The SMS provides monitoring of specified/identified loading conditions to which the charging component of the facilities contribute. From the monitored data the SMS calculates charging capacity limits and those limits are transmitted to the IC's control system. It is expected tha the IC's control system maintain the charging level to the level provided. If the IC does not comply with the provided limits the Distribution Provider will mitigate this condition at its discretion including, but not limited to disconnecting the IC from the grid utilizing the dedicated remote automated switched installed exclusively for the storage facility.

Refer to Attachment 1 and Attachment 2 for scope description and associated project cost responsibility of these Distribution Upgrade(s).

Please note that the ability to charge at any time may not be attainable even when customers agree to pay the cost to implement substation and/or distribution system upgrades. This is

because the increase in load, system modification or changes in load profiles will cause limitations on other parts of the distribution and transmission system to be exceeded.

## **E. Short-Circuit Duty Results**

Short-circuit studies were performed to determine the fault duty impact of adding the Phase II projects to the Transmission System and to ensure system coordination. The fault duties were calculated with and without the projects to identify any equipment overstressed conditions. Once overstressed circuit breakers are identified, the fault current contribution from each individual project in Phase II is determined. Each project in the cluster will be responsible for its share of the upgrade cost based on the rules set forth in Section 4 of the GIP.

### **1. Short-Circuit Duty Study Input Data**

The IC provided technical data for the identified generator as specified in Table A.1. The technical data provided by the IC were compared against the manufacturer data obtained by SCE. Upon SCE's comparison, it was determined that the technical data provided by the IC matched the generator manufacturer data obtained by SCE. Please note that for this study, SCE used the generator manufacturer data obtained by SCE.

#### Inverter Based Generation Data for Each Generation Unit

Maximum fault contribution: 

### **2. Short-Circuit Duty Study Results**

All bus locations where the Phase II projects increase the SCD by 0.1 kA or more and where duty was found to be in excess of 60% of the minimum breaker nameplate rating are listed in the Area Report (Appendix H). These values have been used to determine if equipment is overstressed as a result of the inclusion of Phase II interconnections and corresponding Network Upgrades and Distribution Upgrades, if any.

However, the Project does not contribute to the duty concerns at hand, and did not get allocated costs for ground grid studies at the flagged Distribution Provider-owned substations

## **F. Preliminary Protection Requirements**

Protection requirements are designed and intended to protect the Distribution Provider's electrical system only. The preliminary protection requirements were based upon the interconnection plan as shown in the one-line diagram depicted in line item #7 in Attachment 1.

The IC is responsible for the protection of its own Generating Facility and must meet the requirements in the SCE Interconnection Handbook provided in Attachment 4.

## **G. Transient Stability Evaluation**

### **1. Area Study Transient Stability Results – 220 kV and above**

Refer to enclosed Area Report in the Phase II report package, for the Phase II transient stability evaluation criteria, and assessment results, respectively, at the 220 kV and above voltage level.

### **2. Area Transient Stability Results – 66 kV**

Refer to enclosed Subtransmission Assessment Report in the Phase II report package for the Phase II transient stability evaluation, criteria, and assessment results at the applicable subtransmission voltage level (66 kV).

3. Area Transient Stability Results – 33 kV or below

At the 33 kV and below voltage level this type of study is not performed.

## H. Deliverability Assessment Results

1. On Peak Deliverability Assessment

The Project does not contribute to any deliverability constraint.

2. Off- Peak Deliverability Assessment

Refer to off-peak reliability assessment.

3. Required Mitigations

No Delivery Network Upgrades are required.

## I. In-Service Date and Commercial Operation Date Assessment

The information provided by the IC in Appendix B requested an ISD of November 2018 and a COD of December 2018. To determine if these dates could be met, an ISD and COD assessment was performed which considered both the QC8 Phase II Interconnection Study process timelines as well as the facilities needed to enable an energy only interconnection of the Project. Details pertaining to FCDS and Interim Deliverability are provided in the section below.

1. Interconnection Process Timelines

To enable physical interconnection, a Generation Interconnection Agreement (GIA) is required. As part of the interconnection Study cycle, a GIA is tendered following completion of the final Phase II Interconnection Study with the timing for tendering such GIA impacted by the ISO's Transmission Planning Deliverability (TPD) Allocation Study<sup>7</sup> and the ISO's Annual Reassessment, if applicable.

The TPD Allocation Study process is scheduled to be completed by April 2017 and if no changes to scope requirements are identified, a letter is provided by the ISO at the end of April 2017 outlining the TPD Allocation Study results. However, if changes to scope requirements are identified as part of the ISO's Annual Reassessment Study process, updates to scope, cost, and schedule are developed and provided in a Reassessment Study Report issued by the end of July. For Projects seeking a GIA with Partial Capacity Deliverability Status (PCDS) or FCDS pursuant to the TPD Allocation Study process, GIA negotiations may commence after the issuance of the letter at the end of April 2017, which outlines the TPD Allocation Study results, or upon issuance of the Reassessment Study Report at the end of July 2017, which updates scope, cost, and schedule. Assuming a three (3) month timeframe for GIA negotiations, after the GIA is tendered, the earliest that an executable GIA can be provided to the IC is August 2017, which is contingent on the IC's acceptance of the TPD Allocation Study results. If the Reassessment Study

---

<sup>7</sup> The TPD Allocation Study Process is estimated to complete in April 2017. The actual date may vary.

process affects the Project, an executable GIA is not expected until November 2017. The timeline for executing a GIA could be further delayed if the IC elects to “park” its IR until the following year’s allocation of TP Deliverability.

**2. Upgrade Timelines Needed for Energy Only Interconnection**

The ISD and COD assessment identified that the following facilities are required in order to interconnect the Project. The month durations shown represent the estimated amount of time needed to design and construct the facilities with the start date of the duration based on the effective date of the GIA, IC granting authorization to proceed (ATP), and IC posting financial security.

**a. Distribution Provider’s Interconnection Facilities – 27 months**

Please refer to Section 1.b of Attachment 1 for details related to the Distribution Provider’s Interconnection Facilities.

**b. Reliability Network Upgrades – None identified.**

**I. Plan of Service Reliability Network Upgrades – None.**

**II. Special Protection Systems (SPS) – None.**

**III. Short-Circuit Duty (SCD) Mitigation**

Short-circuit duty operation mitigation took into account new generation projects which have executed GIAs, approved transmission system upgrades fully permitted and under construction, and new generation projects including QC8 Phase II Projects which do not yet have an executed GIA. The study results for these operational studies are provided in Section II of the Generation Sequencing Implementation (GSI) Short-Circuit Duty evaluation (Appendix G). Based on the study results, upgrades/mitigation are not required to be in place in order to enable energy only interconnection of this Project.

SCD mitigation will be continuously evaluated as part of ongoing GIA negotiations with queued generation projects to properly define the actual trigger of SCD mitigation based on the actual execution of GIAs and development of generation facilities.

**c. Voltage Support Mitigation**

No required voltage support upgrades were identified to enable this Project to interconnect.

**d. Distribution Upgrades – 27 months**

- [REDACTED]
- [REDACTED]
- [REDACTED]
- [REDACTED]

Refer to Section 1.b of Attachment 1 for details

### 3. Conclusion

Based on the GIA execution timelines and milestone timelines to design and construct the facilities noted above, the IC's requested ISD of November 2018 and COD of December 2018 are not achievable. Following the standard process, this would result in a best case in-service date of November 1, 2019 depending on TPD study results. Such dates are beyond the requested In-Service Date, the result is consistent with the conclusion provided in the Project's Phase I Interconnection Study report. Assuming the earliest that an executable GIA can be provided to the IC is August 2017, which is contingent on the IC's acceptance of the 2017 TPD Allocation Study results.

### J. Timing of Full Capacity Deliverability Status, Interim Deliverability, Area Constraints, and Operational Information

The IC elected Option B with FCDS for their Project. Timing of obtaining the requested FCDS is dependent on the completion of Delivery Network Upgrades. Until such time that the Delivery Network Upgrades are completed and placed into service, the Project may be granted interim deliverability based on annual system availability. The sections below provide a discussion of the timing of FCDS, interim deliverability, area constraints, and operational information.

#### 1. System Upgrades Required for Full Capacity Deliverability Status

In order to provide for Full Capacity Deliverability Status, the following facilities are required in addition to the Reliability Network Upgrades in Section J.2 of this report.

- a. Triggered Delivery Network Upgrades – None.
- b. Delivery Network Upgrades Triggered by Earlier Queued Projects – None.
- c. Approved Transmission Upgrades – None.
- d. Transmission Upgrades outside the ISO Controlled Grid – None.

#### 2. Interim Operational Deliverability Assessment for Information Only

The operational deliverability assessment was performed for study years 2017 ~ 2020 by modeling the Transmission and generation in service in the corresponding study year. For details of the Transmission and generation assumption, refer to Section E.3 of the Area Report. No deliverability issues were identified. The Project will have the deliverability status as granted by the Transmission Plan Deliverability allocation.

### K. Distribution Provider's Interconnection Facilities, Network Upgrades, and Distribution Upgrades

Please see Attachment 1 for the Distribution Provider's IFs, RNUs, DNU, and DU allocated to the Project. Please note that the Distribution Provider will not "reserve" the identified IF's for the proposed POI. The identified scope/facilities will be allocated to the Project upon the successful execution of the GIA and the Distribution Provider has completed the detailed design and engineering of the facilities according to tariff timelines.

## **L. Cost and Construction Duration Estimates**

To determine the cost responsibility of each generation project in Phase II, the ISO developed cost allocation factors (Attachment 3) for RNUs, Local Delivery Network Upgrades (LDNUs), and Area Delivery Network Upgrades (ADNUs). Attachment 2<sup>8</sup> provides the 'constant' 2016 dollars and their escalation to the estimated COD year for IFs, RNUs, DNUUs, and DUs, which the Project was allocated cost.

The IC should note that any RNUs above the \$60k/MW repayment cap allocated to the Project may be assessed 35% Income Tax Component of Contribution (ITCC), in addition to the 35% ITCC assessed to the Distribution Provider's IFs and DUs assigned to the Project. For your information, Attachment 2 contains a potential ITCC estimate<sup>9</sup> based on the final Phase II cost in this study. It does not represent the "maximum ITCC exposure" to the Project. Attachment 2 provides an estimated non-reimbursable RNU cost that would be subject to ITCC, taking into account the maximum cost responsibility for Network Upgrades. The maximum ITCC assessed to the Project will be addressed, calculated, and included during the GIA development phase after the IC submits the TP Deliverability Allocation Study Process options form confirming to accept, decline, or park the allocation of deliverability awarded to the Project.

## **M. SCE Technical Requirements**

The IC is responsible for the protection of its own system and equipment and must meet the requirements in the SCE Interconnection Handbook provided in Attachment 4.

The IC is responsible for complying with IEEE 519 harmonic impact limits to Distribution Provider's Distribution System (related retail service rules, such as Rule 2).

## **N. Environmental Evaluation, Permitting, and Licensing**

Please see Appendix K of the Area Report.

## **O. Affected Systems Coordination**

Please see Section H of the Area Report.

## **P. Items not covered in this study**

### **1. Conceptual Plan of Service**

The results provided in this study are based on conceptual engineering and a preliminary POS and are not sufficient for permitting of facilities. The POS is subject to change as part of detailed engineering and design.

### **2. This study does not include analysis related to the power output rate of change that may occur due to the following or other conditions:**

- System morning start up for solar systems. That is when each morning the generating facility commences to generate and export electrical energy to the distribution system.

---

<sup>8</sup> For Energy Storage Projects the Attachment 2 includes upgrade(s) identified from the "Charging" analysis.

<sup>9</sup> The maximum ITCC exposure applies ITCC (35%) to the assigned DUs and Distribution Provider's IF. For Network Upgrades, costs that are not subject to transmission credits and/or exceed the \$60k/MW cap will be subject to ITCC (35%). For an Option (A) or Option (B) Generating Facility: the maximum ITCC exposure is calculated by applying the following formula:  $(IF * 35\%) + ((RNU \text{ Costs} - (\text{Project MW} * (\$60\text{k}/\text{MW}))) * 35\%) + (DU * 35\%)$ .

- **Cloud Cover.** Solar generating facilities have significant generation output variation (Variability) which can have an impact on distribution system voltage profiles.
- **The customer's generating facility will have equipment, software, and the appropriate controls as in place to be able to control the generation output rates of change, as specified by SCE, in order to maintain appropriate voltage levels under all conditions including, but not limited to, the conditions identified above. Upon execution of the appropriate Interconnection Agreement, SCE will provide the Interconnection Customer the required ramp rate control parameters. The ramp rate controls will be a function of the generation penetration on the distribution system as well as SCE's distribution system configuration but other parameters may be considered. Therefore, changes to the ramp rate control scheme may be required from time to time as required by increased in generation, changes in the distribution system topology, or other changes in the Distribution System.**

### 3. SCE Distribution System Operational Flexibility

It should be noted that the study results disclosed in this report are dependent upon the system conditions known at the point in time the study is conducted. Given that the system conditions could very well change because of the dynamic nature of the Distribution System after issuance of this report; a new operational/technical study may be needed.

### 4. IC's Technical Data

The study accuracy and results for the Phase II Interconnection Study are contingent upon the accuracy of the technical data provided by the IC. Any changes from the data provided could void the Phase II Interconnection Study results.

### 5. Study Impacts on Neighboring Utilities

Results or consequences of this Phase II Interconnection Study may require additional studies, facility additions, and/or operating procedures to address impacts to neighboring utilities and/or regional forums. For example, impacts may include but are not limited to Western Electricity Coordinating Council (WECC) path ratings, SCD outside of the ISO Grid, and SSR. Refer to Affected Systems Coordination Section of the Area Report for additional information.

### 6. Use of and/or Crossing Distribution Provider's Property

The IC is responsible for acquiring all property rights necessary for the IC's Interconnection Facilities, including those required to cross the Distribution Provider's property. This Phase II Interconnection Study does not include the method or estimated cost to the IC of Distribution Provider mitigation measures that may be required to accommodate any proposed crossing of Distribution Provider's property. The crossing of Distribution Provider property rights shall only be permitted upon written agreement between the Distribution Provider and the IC at the Distribution Provider's sole determination. Any proposed crossing of the Distribution Provider's property rights will require a separate study and/or evaluation, at the IC's expense, to determine whether such use may be accommodated.

### 7. SCE Interconnection Handbook

The IC shall be required to adhere to all applicable requirements in the SCE Interconnection Handbook. These include, but are not limited to, all applicable protection, voltage regulation, VAR correction, harmonics, switching and tagging, and metering requirements.

#### 8. Western Electricity Coordinating Council (WECC) Policies

The IC shall be required to adhere to all applicable WECC policies including, but not limited to, the WECC Generating Unit Model Validation Policy.

#### 9. System Protection Coordination

Adequate Protection coordination will be required between Distribution Provider-owned protection and IC-owned protection. If adequate protection coordination cannot be achieved, then modifications to the IC-owned facilities (i.e., Generation-tie or Substation modifications) may be required to allow for ample protection coordination.

#### 10. Standby Power and Temporary Construction Power

The Phase II Study does not address any requirements for standby power or temporary construction power that the Project may require prior to the ISD of the Interconnection Facilities. Should the Project require standby power or temporary construction power from the Distribution Provider prior to the ISD of the IFs, the IC is responsible to make appropriate arrangements with the Distribution Provider to receive and pay for such retail service.

#### 11. Licensing Cost and Estimated Time to Construct Estimate (Duration)

The estimated licensing cost and durations applied to this Project are based on the Project's scope details presented in this Phase II study. These estimates are subject to change as the Project's environmental and real estate elements are further defined. Upon execution of the GIA, additional evaluation including but not limited to preliminary engineering, environmental surveys, and property right checks may enable licensing cost and/or duration updates to be provided.

#### 12. Ground Grid Analysis

A detailed ground grid analysis will be required as part of the detailed engineering for the Project at the Distribution Provider's substations whose ground grids were flagged with duty concerns.

#### 13. Applicability

This document has been prepared to identify the impact(s) contributions of the Project on the Distribution Provider's Distribution System; as well as establish the technical requirements to interconnect the Project to the POI that was evaluated in the Phase II Study for the Project. Nothing in this report is intended to supersede or establish terms/conditions specified in the GIAs agreed to by the Distribution Provider, ISO, and the IC.

#### 14. Process for Initial Synchronization Date/Trial Operation Date and COD of the Project

The IC is reminded that the ISO has implemented a New Resource Implementation (NRI) process that ensures that a generation resource meets all requirements before Initial Synchronization Date/Trial Operation Date and COD. The NRI uses a bucket system for deliverables from the IC that are required to be approved by the ISO. The first step of this process is to submit an "ISO Initial Contact Information Request form" at least seven (7) months in advance of the planned Initial Synchronization Date. Subsequently an NRI project number will be assigned to the Project for all future communications with the ISO. The Distribution Providers have no involvement in this NRI process except to inform the IC of this process requirement. Further information on the NRI process can be obtained from the ISO Website using the following links:



New Resource Implementation webpage:

<http://www.ISO.com/participate/Pages/NewResourceImplementation/Default.aspx>

NRI Checklist:

<http://www.ISO.com/Documents/NewResourceImplementationChecklist.xls>

NRI Guide:

<http://www.ISO.com/Documents/NewResourceImplementationGuide.doc>

#### 15. Potential Changes in Cost Responsibility

The IC is advised that interconnection of its proposed Generating Facility may be dependent upon the construction of certain Network Upgrades, which are currently the obligation of projects ahead of its proposed Generating Facility in the interconnection application queue. These other potential network upgrades are referenced in Section B.5 of the Area Report and outlined in Attachment 2 to the ICs final Phase I or Phase II Study Report (Appendix A).

Whether the IC becomes responsible for all or a portion of these other potential network upgrades depends upon several factors, some of which are unknown at the time of this study. However, in an effort to alert the IC to its maximum cost responsibility for Network Upgrades, were these other potential network upgrades to become the obligation of the IC, SCE has included the IC's proportionate cost responsibility for these upgrades under the other potential network upgrades section in Attachment 2 to this report. The IC is not required to post Interconnection Financial Security for these other potential network upgrades, but the prospective obligation to finance and construct these other potential network upgrades is included in the IC's maximum cost responsibility.

The obligation to finance and construct these other potential network upgrades is governed by Sections 4.6.8 and 10.3.2 of the GIP and 14.2.2 of the GIDAP. Both the GIP and GIDAP contain similar language, which is summarized as follows:

- 1) If the earlier-queued generating facilities that have cost responsibility for the other potential network upgrades withdraw prior to executing a GIA (or the filing of an unexecuted GIA at FERC), the following will occur:
  - a. The ISO and SCE will evaluate whether the other potential network upgrades are still needed to support the interconnection for later-queued generating facilities
  - b. The ISO and SCE will reapportion the cost of the other potential network upgrades to the later-queued generating facilities that require the upgrades
  - c. Steps (a and b) will occur as a result of the ISO's Annual Reassessment as set forth in Section 7.4 of GIDAP and Section 6.2.9.2 of the ISO's GIDAP business practice manual
  - d. The reapportioned cost of the other potential network upgrades will be reflected in the reassessment report as outlined in the ISO's Annual Reassessment process, which will be reflected in the GIAs of the responsible parties
- 2) Please refer to Section 10.3.2 of the GIP and Section 14.2.2 of the GIDAP for additional requirements regarding treatment of other potential network upgrades for ICs that select an Option (B) Generating Facility.

16. Additional limitations may be driven by the ISO market and distribution system operations.

17. Please note that the Distribution Provider has made its best efforts to convey as much information as possible based on information provided by the IC about its proposed Project. The information

contained herein may indicate to ICs that a project of its magnitude may be better suited to interconnect at higher voltage levels, or downsize as to not incur significant amount of restrictions. Any determination to change POIs or downsize is purely at the IC's discretion and would be subject to a Distribution Provider's material modification review pursuant to the tariff.

**Attachment 1**  
**Interconnection Facilities, Network Upgrades and Distribution Upgrades**  
Please refer to separate document

**Attachment 2**  
**Escalated Cost and Time to Construct for Interconnection Facilities, Reliability Network Upgrades, Delivery Network Upgrades, and Distribution Upgrades**  
Please refer to separate document

**Attachment 3  
Not Used**

No network upgrade costs were assigned to the project

**Attachment 4**  
**SCE Interconnection Handbook**  
Preliminary Protection Requirements for Interconnection Facilities are outlined in the SCE  
Interconnection Handbook (separate document)

**Attachment 5**  
**Short-Circuit Duty Calculation Study Results**  
Please refer to the Appendix H of the Area Report

**Attachment 6**  
Not Used



**Attachment 7**  
**Not Used**

**Attachment 8**  
**Subtransmission Assessment Report**  
Please refer to separate document